

SINGLE GABLE CARPORT

WIND LOADING OF:
W 50C -C2

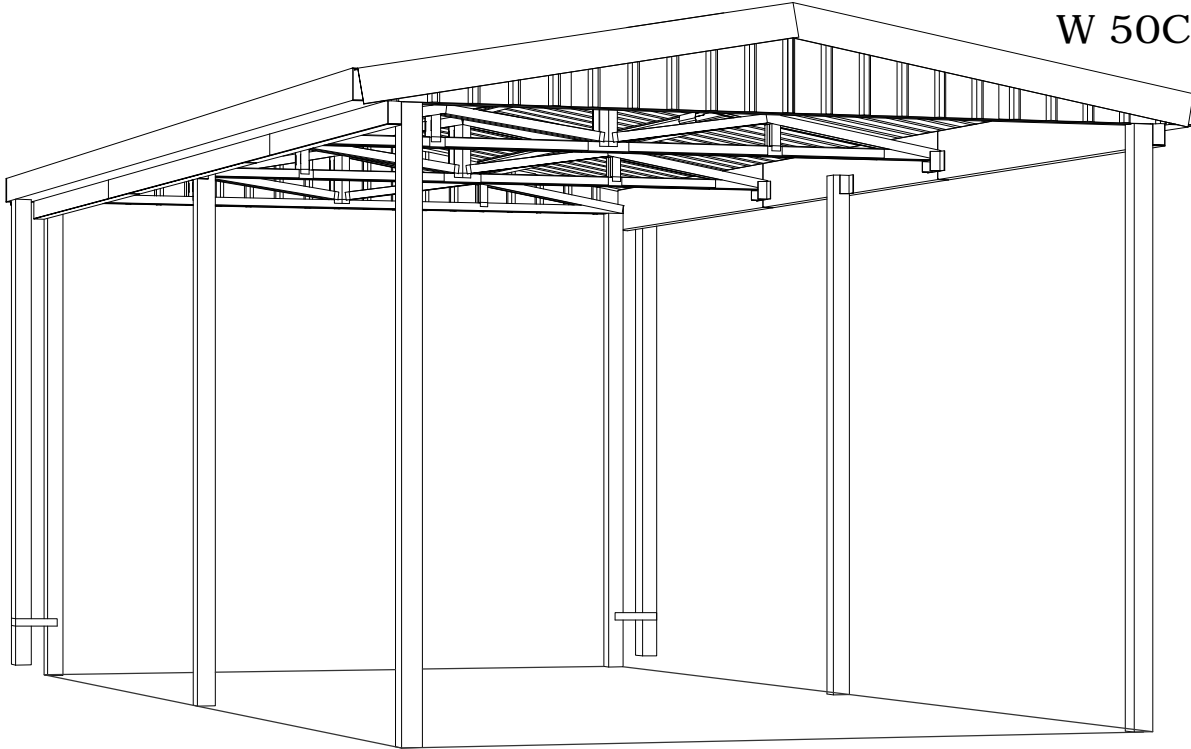

INTERNAL FRAMING:

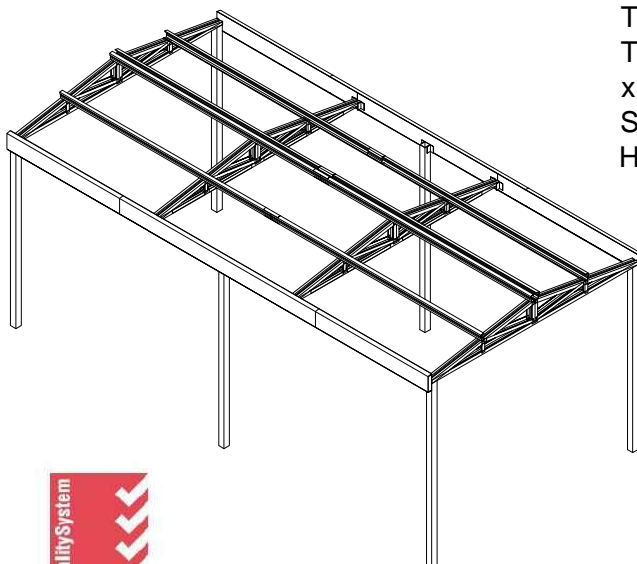

THE ROOF PURLINS AND WEB TRUSSES FOR THIS CARPORT ARE CONSTRUCTED FROM 80mm x 40mm GALVANISED STEEL CHANNEL SECTION, SIMILAR TO SECTIONS USED IN DOMESTIC STEEL HOUSE FRAMING.



MOST OF THESE CHANNEL SECTIONS HAVE BEEN BRANDED WITH PART NUMBERS FOR EASY IDENTIFICATION, AND PACKED IN SEPARATE BUNDLES FOR EACH FRAME TYPE. (REFER TO THE PARTS LIST ON PAGE 5)

SITE PREPARATION

- Local council approval must be obtained prior to construction of the carport. Once you have selected your site you will need to create and lodge a site plan to your local council or certifier. You will also have to attach a copy of the engineering drawings at the back of these instructions to your site plan.
- The site for the carport must be level, refer to concrete and foundation notes on attached engineers drawings.

GENERAL INSTRUCTIONS

- Before commencing any assembly, read through these instructions and engineers drawings in detail to gain a thorough understanding of assembly methods and associated details.
- Some components have been pre-punched. Some 10mm holes will still have to be drilled. It may be easier to drill a small pilot hole first.
- Measure, and check off all components using the parts lists on pages 4, 5 & 6 prior to commencement. To prevent damage in transit, some components may be packed inside others, almost hidden. Carefully examine inside each component to ensure that you have located every item. If a discrepancy is found, contact Absco industries immediately.

- SPIRIT LEVEL
- SPANNERS
- FELT PEN, STRING LINE
- TAPE MEASURE
- CLAMP OR VICE GRIPS
- SILICONE, CHALK
- 12mm MASONRY DRILL BIT

TOOLS REQUIRED



10mm DRILL BIT AND
MASONRY DRILL BIT



A NOTE ON SAFETY

- Some parts may have sharp edges. It is advisable to wear gloves when handling these items and safety glasses if drilling holes. Sensible shoes are highly recommended.
- It is highly recommended to erect the carport with at least two or more people.



HELPFULL HINTS

1. PART NUMBERS.

AS NOTED ON PAGE ONE, PART NUMBERS HAVE BEEN PRINTED ON MOST 80 x 40 CHANNEL SECTIONS. ALL OTHER COMPONENTS HAVE NOT BEEN MARKED WITH PART NUMBERS, BUT CAN BE IDENTIFIED BY THEIR DESCRIPTION, SIZE AND SKETCHES PROVIDED ON PAGES THREE, FOUR AND FIVE OF THIS INSTRUCTION.

2. ALL COMPONENTS PRE-CUT TO SIZE

DO NOT CUT ANY COMPONENTS TO A DIFFERENT SIZE, UNLESS IT IS CLEARLY NOTED IN THIS INSTRUCTION TO DO SO. DIMENSIONS IN THIS ASSEMBLY INSTRUCTION ARE EXACT, WHERE AS DIMENSIONS NOTED ON THE ENGINEERING PLANS ARE APPROXIMATE. DOUBLE CHECK THAT YOU HAVE THE CORRECT COMPONENT FOR THE CORRECT LOCATION.

3. SELF DRILLING SCREWS



10 X 16 HEX HEAD TEK SCREW FOR GENERAL USE.



10 X 16 HEX HEAD TEK SCREW WITH NEOPRENE WASHER FOR SECURING ROOF SHEETS TO FRAMEWORK.



PHILLIPS HEAD TEK SCREW - USE ON OUTSIDE OF FRONT FRAMEWORK TO MAINTAIN A SMOOTH SURFACE TO SECURE SHEETING TO.

THE STRUCTURE IS ASSEMBLED USING THESE SELF DRILLING TEK SCREWS. ALL ROOF AND WALL SHEETS ARE PAN FIXED. ie SCREW THROUGH THE FLAT PAN OF THE SHEET INTO THE FRAMEWORK.

SCREW DRIVER BITS ARE INCLUDED FOR USE IN YOUR DRILL. REFER TO THE ATTACHED ENGINEERING DRAWINGS FOR THE QUANTITY OF SCREWS REQUIRED PER CONNECTION.

4. MISSING PARTS

TO PREVENT DAMAGE IN TRANSIT, SOME ITEMS ARE PACKED INSIDE OTHERS. eg. SOME FLASHINGS MAY BE INSIDE CHANNEL SECTIONS, OTHER ITEMS MAY BE PACKED INSIDE GUTTERS, SOME ROOF SHEETS PACKED ON TOP, SOME ON THE BOTTOM ETC. BE VERY THOROUGH WHEN CHECKING AND LOCATING ALL COMPONENTS.

IDENTIFICATION OF PARTS

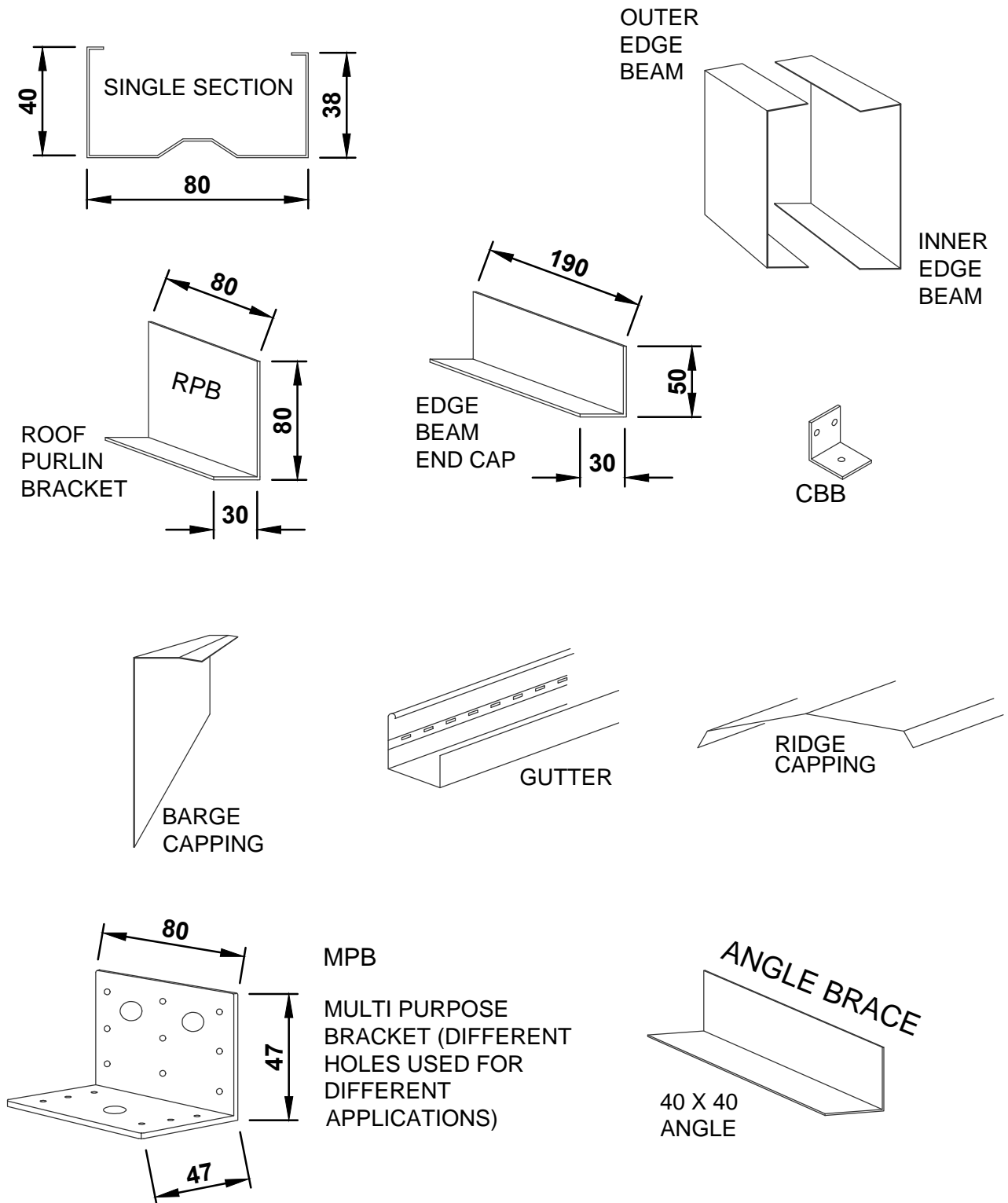

COMPONENTS PACKING LIST - CHECK OFF ALL COMPONENTS

GCPSW50 SINGLE GABLE CARPORT - PARTS LIST				
QTY	DESCRIPTION	MATERIAL	LENGTH	CHECK
8	TRUSS TOP CHORD	80 X 40 CHANNEL	1465 mm	
4	TRUSS BOTTOM CHORD	80 X 40 CHANNEL	2900 mm	
8	TRUSS CENTRE VERTICAL	80 X 40 CHANNEL	255 mm	
8	TRUSS DIAGONAL BRACE	80 X 40 CHANNEL	670 mm	
8	TRUSS MID VERTICAL	80 X 40 CHANNEL	130 mm	
4	TRUSS OUTER INFILL (CENTRE TRUSS ONLY)	80 X 40 CHANNEL	450 mm	
4	TRUSS INNER INFILL (CENTRE TRUSS ONLY)	80 X 40 CHANNEL	600 mm	
8	ROOF PURLINS	80 X 40 CHANNEL	2960 mm	
4	ROOF PURLIN JOINERS	80 X 40 CHANNEL	200 mm	
6	INNER SIDE BEAMS	"200mm " CHANNEL	1973 mm	
4	OUTER SIDE BEAMS	"190mm" CHANNEL	1585 mm	
2	OUTER SIDE BEAMS	"190mm" CHANNEL	2750 mm	
6	COLUMNS (Add 300mm or 600mm if required)	75 X 75 RHS.	2250 mm	
16	ROOF SHEETS	SHEETING	1540 mm	
4	GABLE SHEETS (2 L/H & 2 R/H)	SHEETING	360 mm	
4	GABLE SHEETS (2 L/H & 2 R/H)	SHEETING	235 mm	
2	DOWNPIPES (Add 300mm or 600mm if required)	100 X 75 DOWNPIPE	2400 mm	
4	GUTTERS	COMPAC GUTTER	3030 mm	
4	BARGE FLASHING	FLASHING	1540 mm	
2	RIDGE CAPPING	FLASHING	3030 mm	
2	DOWNPIPE DROPS	100 X 75 DROPS		
2	DOWNPIPE STRAPS	FLAT STRIP	600 mm	
16	GUTTER BRACKETS	COMPAC		
4	GUTTER STOP ENDS	COMPAC		
4	TRUSS TOP JOINING PLATES	80 X 1.0mm PLATE	160mm	
1	ROLL OF ROOF STRAPPING	ROLL	30M	
16	PURLIN TO TRUSS BRACKETS	80 X 30 ANGLE	75 mm	
20	MULTI PURPOSE BRACKETS (MPB)	80 X 80 ANGLE	75 mm	
4	EDGE BEAM END CAPS	55 X 30 ANGLE	190 mm	

COMPONENTS PACKING LIST - CHECK OFF ALL COMPONENTS

GCPSW50 SINGLE GABLE CARPORT - PARTS LIST				
QTY	DESCRIPTION	MATERIAL	LENGTH	CHECK
12	C/PORT BASE BRACKET (CBB) 12mm HOLES	75 X 75 ANGLE	65 mm	
12	ANGLE BRACE (ROOF TO COLUMN BRACE)	40 X 40 ANGLE	700 mm	
8	ANGLE BRACE (FLY BRACING)	40 X 40 ANGLE	270 mm	
4	ANGLE BRACE (FLY BRACING)	40 X 40 ANGLE	450 mm	
12	DYNABOLTS	D12		
24	BOLTS & NUTS	M10	20 mm	
48	WASHERS	M10		
200	WAFER HEAD SELF DRILLING SCREWS	10 X 16		
1000	HEX HEAD TEK SCREWS	10 X 16		
300	HEX HEAD TEK SCREWS WITH NEO WASHERS	10 X 16		
50	RIVETS			

A) FOOTINGS (PIERS)

PREPARE SITE AND MARK OUT FOOTING (PIER) POSITIONS AS SHOWN BELOW. DIG FOOTINGS, THEN BOX SURROUNDS TO FORM A LEVEL FLAT CONCRETE SURFACE FOR FIXING FRAMEWORK TO.

IT IS RECOMMENDED THAT THE CONCRETE SHOULD BE BOXED 100mm ABOVE GROUND LEVEL TO ALLOW FOR A FUTURE SLAB.

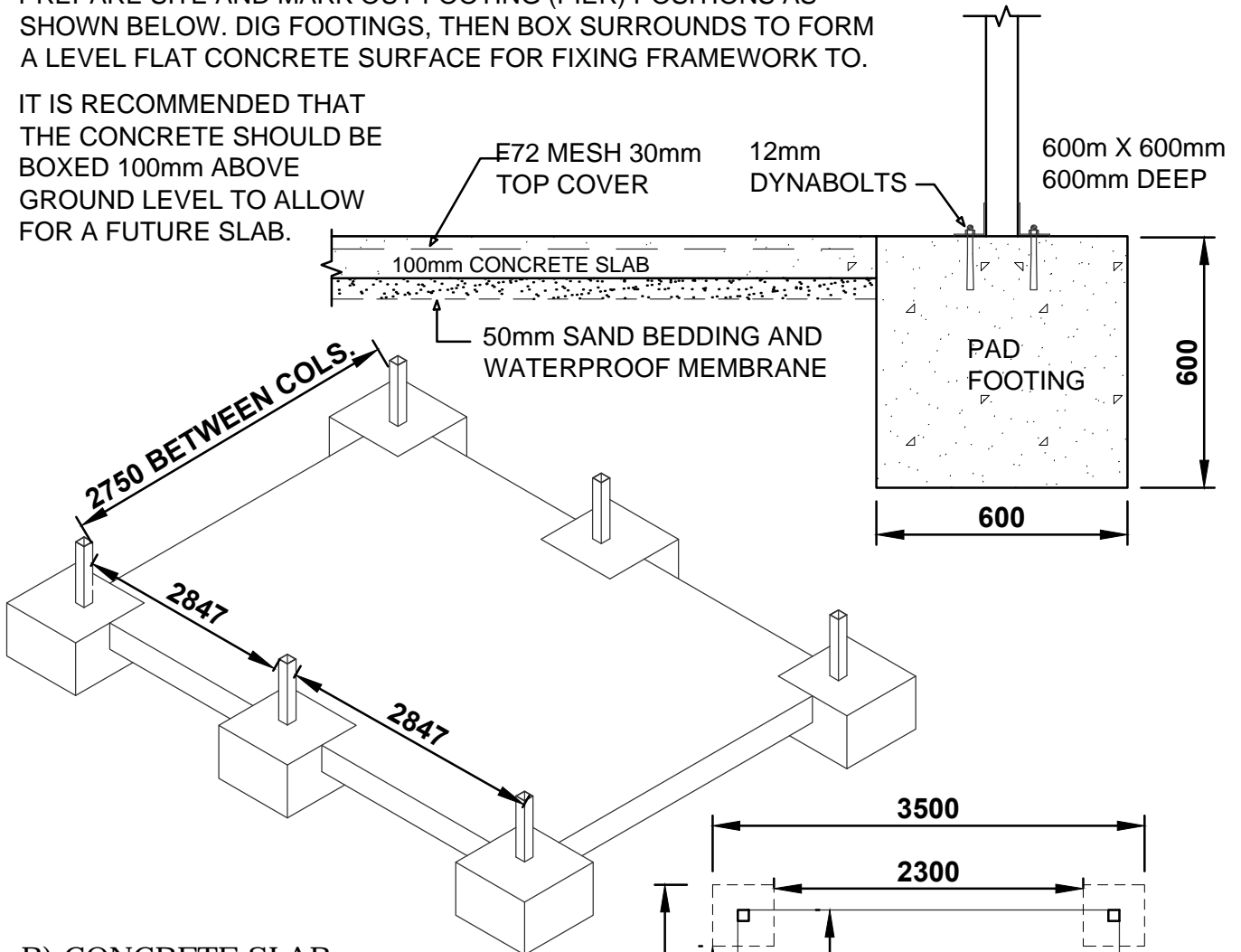

B) CONCRETE SLAB

PREPARE THE FOOTINGS AS NOTED IN (A) ABOVE, THEN POUR A PERFECTLY LEVEL SLAB TO THE DIMENSIONS SHOWN. (5920mm X 2900mm)

ALTERNATIVELY, YOU MAY PREFER THE SLAB TO FINISH FLUSH WITH THE OUTSIDE OF THE FOOTINGS, THEREFORE THE SLAB WILL MEASURE 3500mm X 6520mm.

THE SLAB SHOULD BE 100mm THICK, REINFORCED WITH F72 MESH LAID 30mm FROM THE TOP. NO EDGE THICKENING IS REQUIRED APART FROM THE FOOTINGS AS DETAILED.

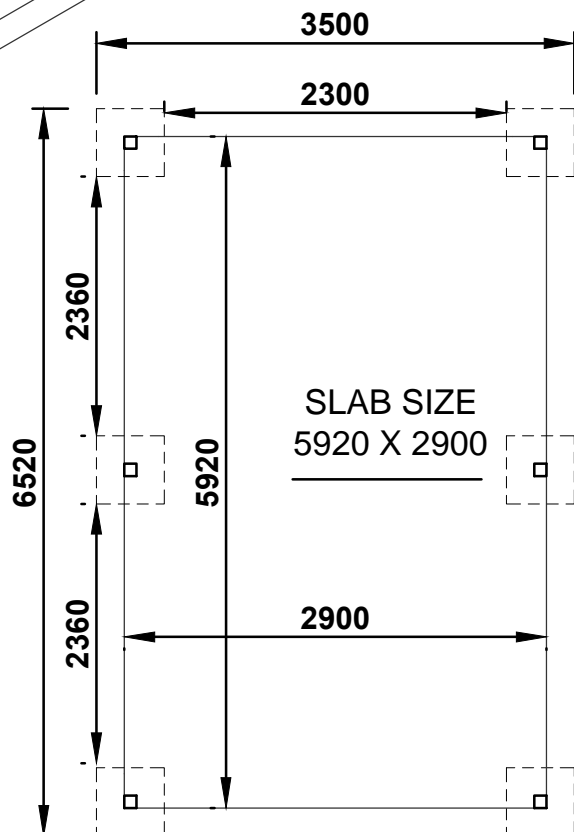

TRUSS ASSEMBLY

FRONT & REAR TRUSS

PARTS REQUIRED (PER TRUSS)

80 x 40 CHANNEL

QTY	PART No	LENGTH
2	C1465	1465mm
1	S2900	2900mm
2	P0255	255mm
2	S0670	670mm
2	P0130	130mm

1 X 160mm X 80 TRUSS JOINING PLATE

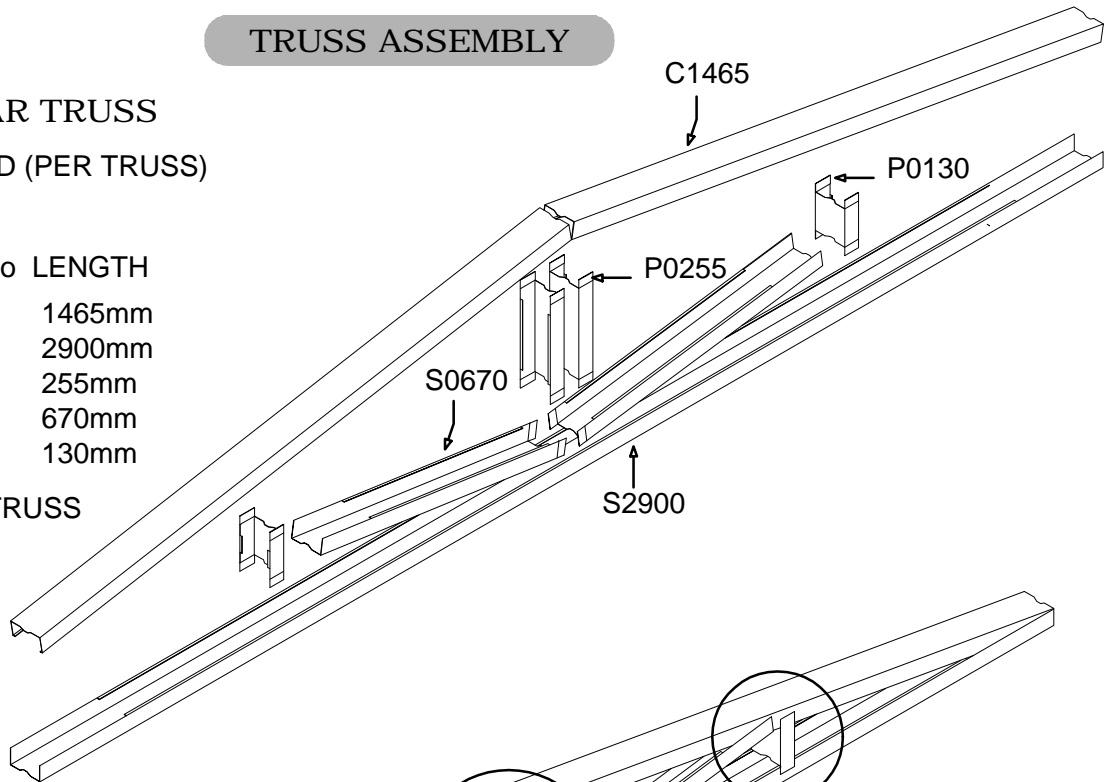

LAY OUT ALL PARTS AS SHOWN. JOIN TOGETHER WITH ONE SCREW AT EACH CONNECTION TO BEGIN WITH. RE-CHECK THAT ALL SECTIONS FIT TOGETHER NEATLY BEFORE SECURING ALL SECTIONS TOGETHER WITH TWO SCREWS PER CONNECTION ON BOTH SIDES OF THE TRUSS.

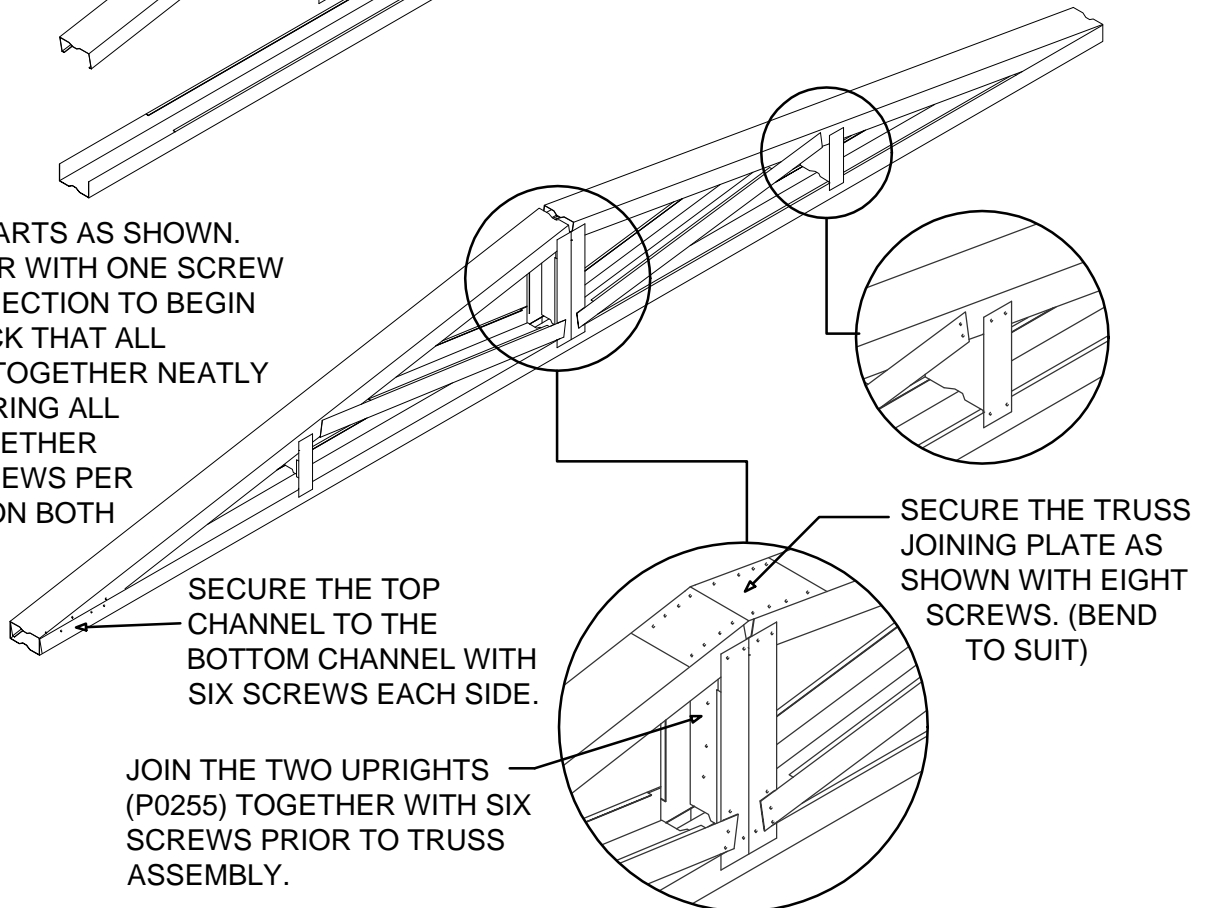

SECURE THE TOP CHANNEL TO THE BOTTOM CHANNEL WITH SIX SCREWS EACH SIDE.

JOIN THE TWO UPRIGHTS (P0255) TOGETHER WITH SIX SCREWS PRIOR TO TRUSS ASSEMBLY.

SECURE THE TRUSS JOINING PLATE AS SHOWN WITH EIGHT SCREWS. (BEND TO SUIT)

SECURE FOUR ROOF PURLIN BRACKETS TO THE TOP OF EACH TRUSS WITH FOUR SCREWS PER BRACKET.

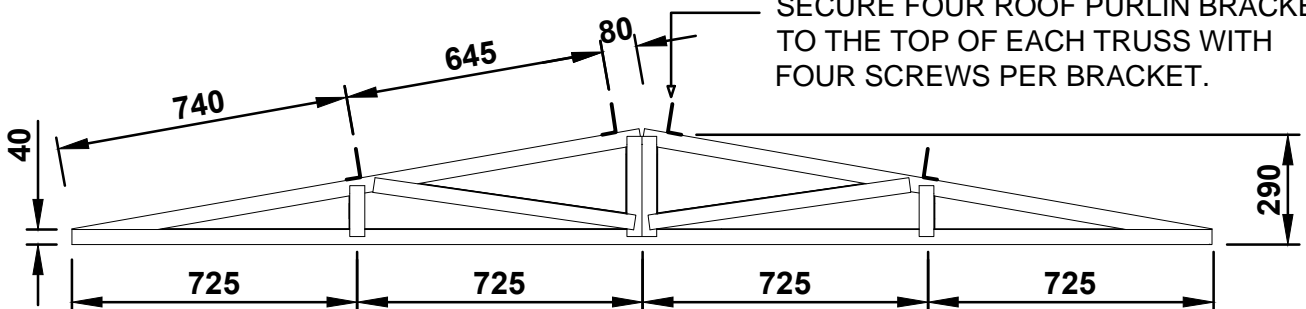

TRUSS ASSEMBLY

CENTRE TRUSS (2 REQUIRED)

PARTS REQUIRED 80 x 40 CHANNEL

QTY	PART No	LENGTH
2	C1465	1465mm
1	S2900	2900mm
2	P0255	255mm
2	S0670	670mm
2	P0130	130mm

ASSEMBLE THE TRUSS EXACTLY THE SAME AS THE REAR AND FRONT TRUSSES, AS DETAILED ON THE PREVIOUS PAGE.

2	C0450	450mm	(CENTRE TRUSS OUTER BASE INFILL)
2	C0600	600mm	(CENTRE TRUSS INNER BASE INFILL)

THEN INSERT THESE FOUR CHANNELS INTO THE BOTTOM OF THE TRUSS AS SHOWN BELOW. THESE CHANNELS WILL PROVIDE ADDITIONAL STRENGTH TO THE CENTRE TRUSS, BUT ARE NOT REQUIRED IN THE FRONT OR REAR TRUSSES.

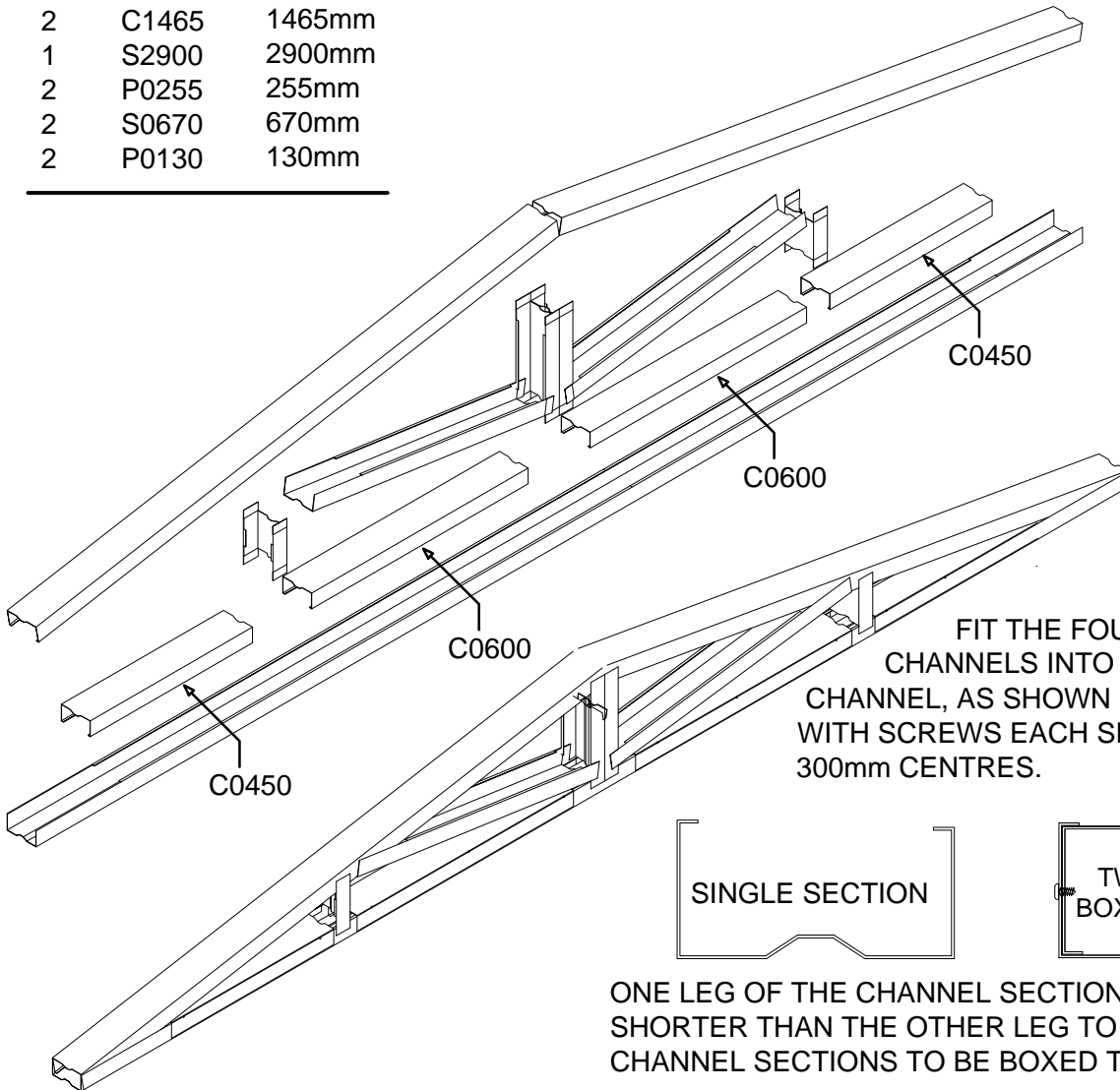

FIT THE FOUR INFILL CHANNELS INTO THE BOTTOM CHANNEL, AS SHOWN BELOW. SECURE WITH SCREWS EACH SIDE AT MAXIMUM 300mm CENTRES.

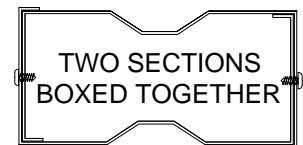
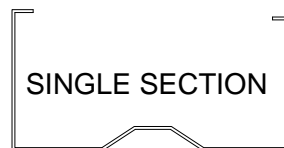

ONE LEG OF THE CHANNEL SECTION IS 2mm SHORTER THAN THE OTHER LEG TO ALLOW TWO CHANNEL SECTIONS TO BE BOXED TOGETHER.

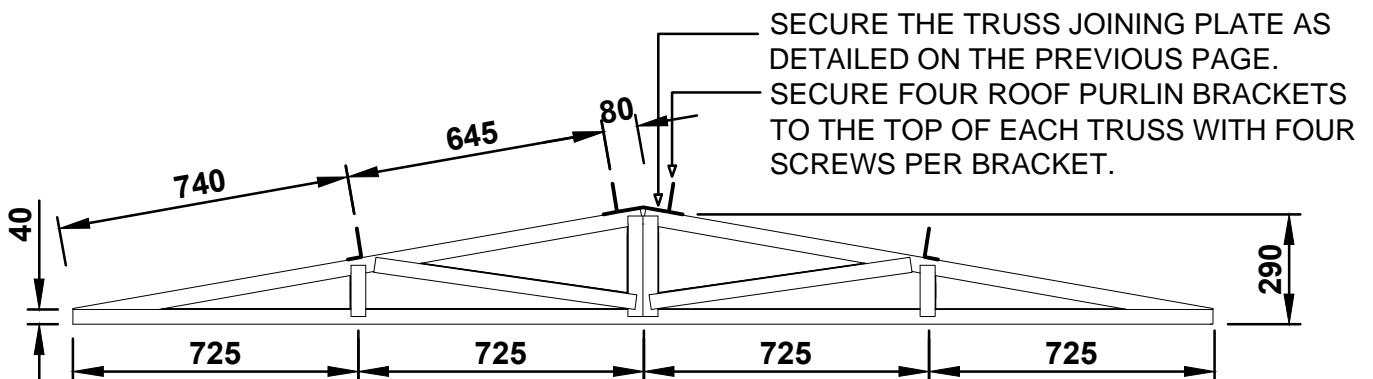

SECURE THE TRUSS JOINING PLATE AS DETAILED ON THE PREVIOUS PAGE. SECURE FOUR ROOF PURLIN BRACKETS TO THE TOP OF EACH TRUSS WITH FOUR SCREWS PER BRACKET.

PARTS REQUIRED (PER SIDE BEAM)

- 3 X INNER SIDE BEAM SECTIONS @ 1973mm LONG
- 1 X OUTER SIDE BEAM SECTIONS @ 2750mm LONG
- 2 X OUTER SIDE BEAM SECTIONS @ 1585mm LONG

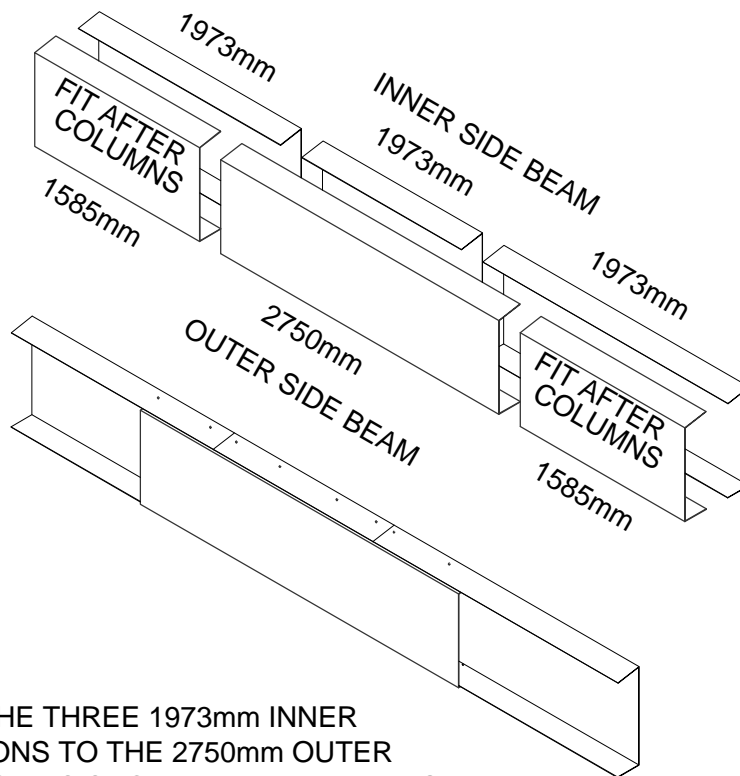

OUTER
SIDE
BEAM

SECURE
TOP AND
BOTTOM
FLANGES
AT 150mm
CENTRES

INNER
SIDE
BEAM

JOIN THE THREE 1973mm INNER SECTIONS TO THE 2750mm OUTER SECTION AS SHOWN. THE REMAINING TWO 1585mm OUTER SECTIONS WILL BE FITTED AT A LATER STAGE, TO ALLOW ACCESS TO SECURING BOTH SIDE BEAMS TO THE COLUMNS.

PREPARE ROOF PURLINS

- PARTS REQUIRED: 80 x 40 CHANNEL
- 8) PART C2960 80 X 40 CHANNELS
 - 4) PART C0200 80 X 40 CHANNELS

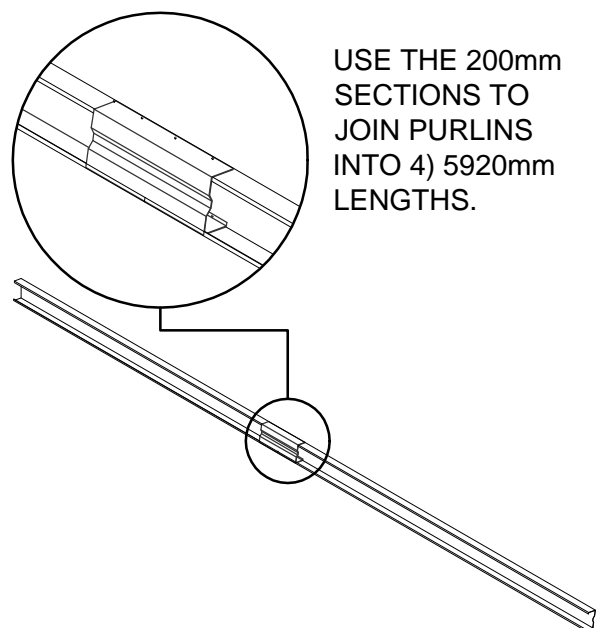

USE THE 200mm SECTIONS TO JOIN PURLINS INTO 4) 5920mm LENGTHS.

ATTACH BASE BRACKETS TO COLUMNS

USING THE COLUMN BASE BRACKETS AS TEMPLATES, DRILL FOUR 10mm HOLES IN EACH COLUMN. JOIN TWO COLUMN BASE BRACKETS TO EACH COLUMN WITH FOUR M10 x 20mm BOLTS, NUTS AND WASHERS, WHICH ARE FITTED FROM INSIDE THE COLUMN.

STANDING THE COLUMNS

AS DETAILED ON PAGE 4, MARK THE COLUMN OUT ON THE CONCRETE. POSITION EACH COLUMN, AND MARK OUT THE BASE BRACKET HOLE POSITIONS ON THE CONCRETE.

USING A 12mm MASONRY DRILL BIT, DRILL THE BASE HOLES AND SECURE EACH COLUMN IN PLACE.

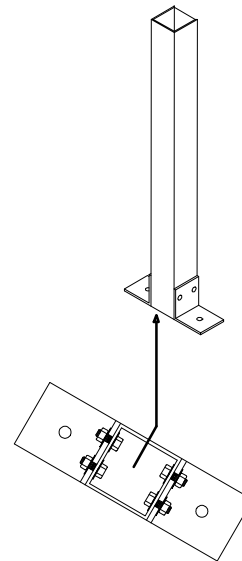

SECURE SIDE BEAMS & FRONT/REAR TRUSSES TO COLUMNS

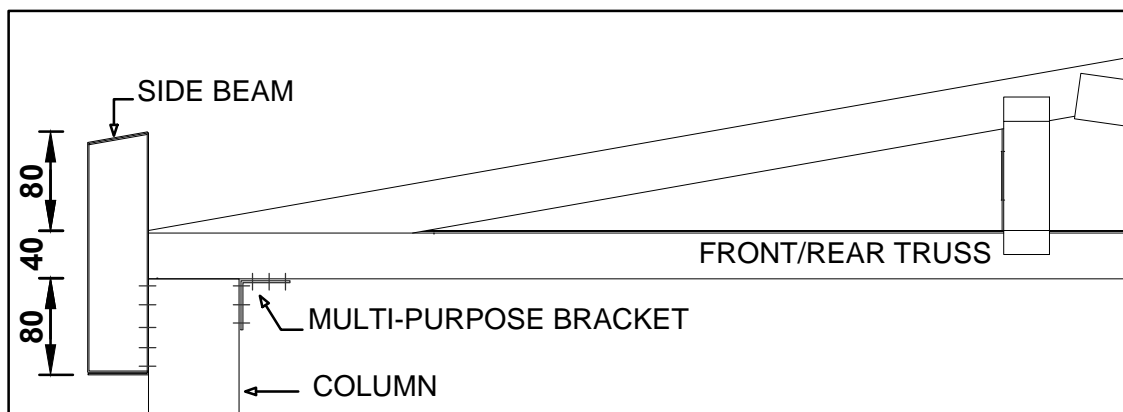

- WITH THE HELP OF ANOTHER PERSON, CONNECT THE FRONT/REAR TRUSSES TO THE COLUMNS, USING A MPB BRACKET AS SHOWN ABOVE.
- LIFT THE SIDE BEAMS IN PLACE, WITH THE PARTIAL OPEN SECTION FACING OUTWARDS. SECURE THESE WITH TEN SCREWS TO EACH COLUMN.
- FIT THE REMAINING 1585mm OUTER SIDE BEAM SECTIONS IN PLACE. CAP THE ENDS OF EACH SIDE BEAM WITH AN EDGE BEAM END CAP ANGLE.

NOTE: THROUGHOUT FRAME CONSTRUCTION, YOU WILL FIND THE STRUCTURE WILL BE UNSTABLE UNTIL THE CONSTRUCTION OF THE FRAME IS FULLY COMPLETED. ENSURE THAT DURING CONSTRUCTION THE FRAMEWORK IS SUFFICIENTLY BRACED USING ROPE OR TIMBER PROPS TO STABILISE AND PREVENT TWISTING OR COLLAPSE.

SECURE CENTRE TRUSS TO SIDE BEAMS

TO MARK THE POSITION OF THE CENTRE TRUSS, RUN A STRING LINE FROM TRUSS TO TRUSS AND MEASURE IN 2960 FROM ONE END OF THE SIDE BEAM. SECURE THREE MPB BRACKETS TO EACH SIDE BEAM AS SHOWN. LIFT THE TRUSS INTO POSITION AND SECURE WITH SCREWS.

POSITION TO THE SAME HEIGHT AS THE FRONT & REAR TRUSSES AS NOTED ON PAGE 8.

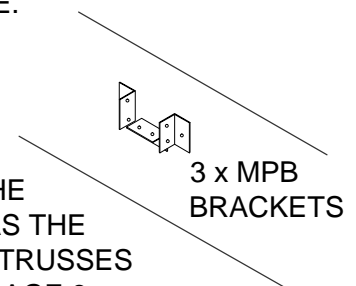

FIT ROOF PURLINS

SECURE ROOF PURLINS IN PLACE WITH FOUR SCREWS AT EACH LOCATION

FIT FLY BRACING

- 8) 40 X 40 X 270
- 4) 40 X 40 X 450

FLY BRACING ANGLES ARE POSITIONED AT 45 DEGREES FROM THE ROOF PURLIN TO THE UNDERSIDE OF EACH FRAME.

FIT ANGLE BRACES

- 8) 40 X 40 X 700

SECURE TWO ANGLE BRACES TO EACH COLUMN WITH FOUR SCREWS EACH END.

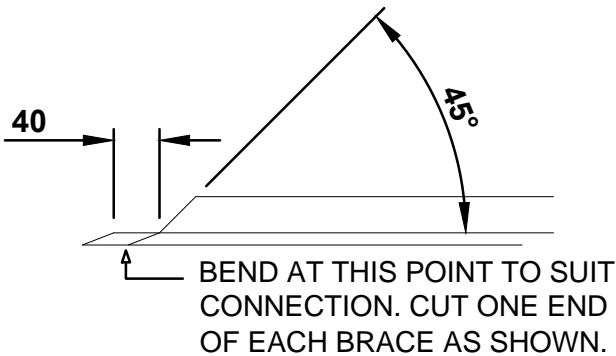

FIT ROOF SHEETING

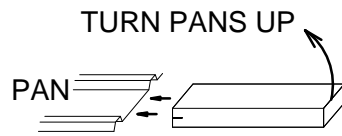

LENGTH OF HARDWOOD WITH 25MM DEEP SAWCUT. USED TO BEND PANS OF SHEETS

- LAY THE ROOF SHEETS ON THE GROUND IN THE SAME CONFIGURATION AS THEY WILL LAY ON THE ROOF. TURN UP THE PANS AT THE RIDGE AS SHOWN ABOVE. THIS WILL PREVENT RAINWATER ENTRY DURING WINDY CONDITIONS
- EACH SHEET IS 773mm WIDE WITH A SHEET TO SHEET COVERAGE OF 740mm. THUS 8 SHEETS = 5920mm WHICH IS THE FRAME SIZE. AS COVERAGE OF SHEETS MAY VARY SLIGHTLY, IT IS IMPORTANT THAT YOU KEEP A CONSTANT CHECK ON YOUR PROGRESS.
- USE ONE SCREW WITH NEO WASHER AT EVERY PAN TO RIDGE AND OUTER PURLINS. USE ONE SCREW WITH NEO WASHER AT EVERY SECOND PAN ON THE CENTRE PURLIN
- LAY THE RIDGE CAPPING CENTRALLY ON THE ROOF, OVERLAPPING THE SECTIONS TO ATTAIN THE REQUIRED LENGTH EQUIVALENT TO THE ROOF SHEETING, AND FIX TO EVERY SECOND RIB OF THE ROOF SHEETING WITH SCREWS AND NEO WASHERS.

NOTE: AVOID WALKING ON THE ROOF SO SHEETING IS NOT DAMAGED. IF IT IS NECESSARY, WALK ONLY ON THE PANS AT PURLIN LOCATIONS AFTER SHEETS HAVE BEEN SECURED.

FIT GABLE SHEETS

4 X SHEETS 360mm
4 X SHEETS 235mm

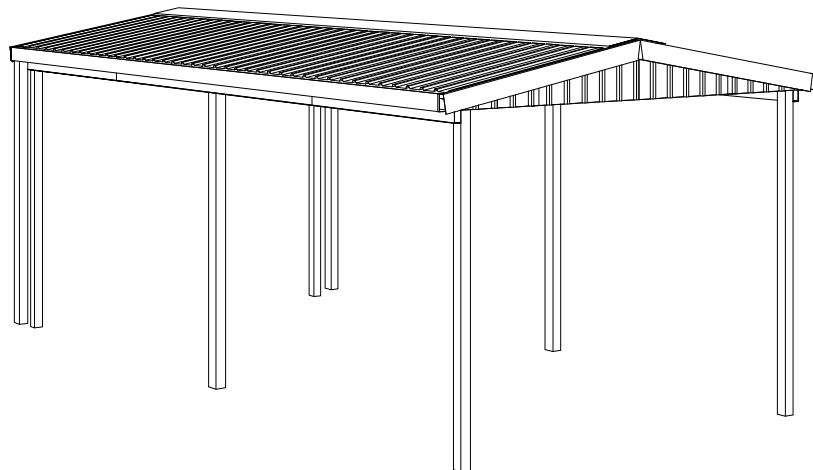

- STARTING WITH THE CENTRE SHEETS, PLACE EACH SHEET SO IT FINISHES FLUSH WITH THE BOTTOM OF THE TRUSS.
- USE SCREWS WITHOUT NEO WASHERS AT EVERY SECOND PAN.
- AVOID FIXING SCREWS CLOSE TO EXISTING SCREWS IN THE TRUSS AS THIS WILL DISTORT THE SHEETING.

FIT GUTTER AND DOWNPIPE

- JOIN LENGTHS OF GUTTER TO MATCH THE LENGTH OF THE SHED BY NOTCHING THE ROLLED EDGE OF ONE TO ALLOW THE OTHER TO SLIDE INTO IT. PUT SILICONE IN THE JOINT THEN USE RIVETS TO FASTEN THE SECTIONS TOGETHER. REPEAT THIS PROCEDURE FOR THE OTHER SIDE.
- MARK THE HOLES TO BE CUT TO ACCEPT THE DOWNPIPE DROP AT THE ENDS YOU SELECT. FIX THE DROP WITH SILICONE AND RIVETS, THEN FIX GUTTER STOP ENDS TO ENDS WITH RIVETS AND SILICONE.
- MARK A LINE 110MM DOWN FROM THE TOP OF THE OUTER PURLINS AT EACH END OF THE SHED. RUN A STRINGLINE BETWEEN THESE MARKS. THIS LINE REPRESENTS THE BOTTOM POSITION OF THE GUTTER BRACKETS, WHICH ARE ATTACHED TO EACH SHEETING RIB. YOU MAY WISH TO ALLOW FOR A SLIGHT FALL TO THE DOWNPIPE POSITION (PERSONAL PREFERENCE)
- FIX GUTTER ONTO BRACKETS EQUALLY AT BOTH ENDS, PUSH TOP OF BRACKET INTO OUTER ROLL OF GUTTER, AND BEND SMALL SUPPORT ARM DOWN TO RETAIN INNER FACE.
- RIVET BRACKETS TO GUTTER THROUGH THE BOTTOM OF EACH BRACKET.
- FIT DOWNPIPES TO DROPS WITH SILICONE AND RIVETS, THEN SECURE TO WALL SHEETING WITH DOWNPIPE STRAP BENT TO SUIT.

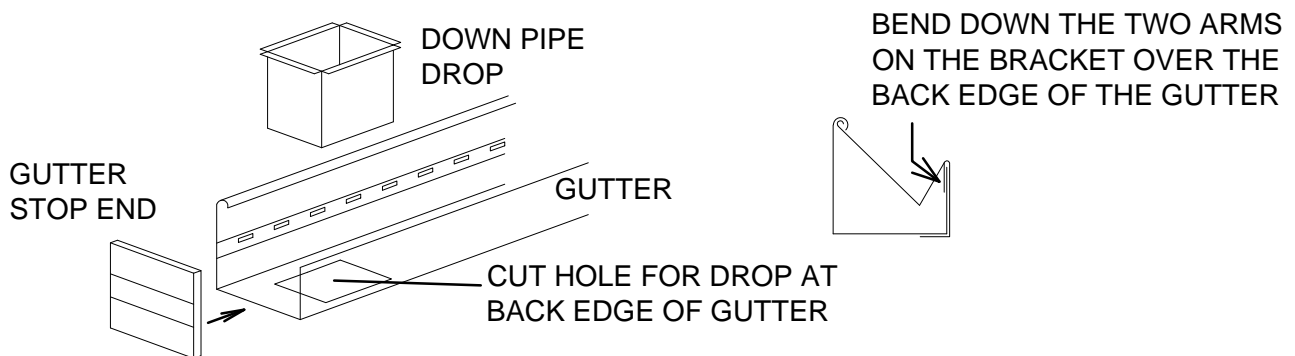

FIT BARGE CAPPING

FIT BARGE TRIMS TO FRONT AND REAR GABLES FIXING THROUGH THE ROOF AT PURLIN LOCATIONS.

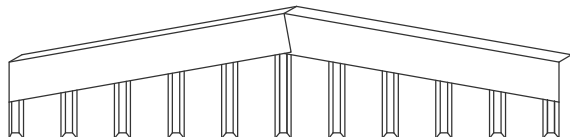

USE THE FOUR EDGE BEAM END CAPS TO COVER THE ENDS OF THE EDGE BEAMS.

IMMEDIATE MAINTENANCE

CLEAN DOWN ALL ROOF AND INTERNAL GUTTER AREAS. METAL FILINGS FROM DRILLING HOLES AND USING SELF DRILLING SCREWS CAN CAUSE DISCOLOURATION AND CORRODE ROOF SHEETS AND GUTTERS.

AUSTRALIA PRODUCT WARRANTY AGAINST DEFECTS

Congratulations on your purchase of an ABSCO SHED

ABSCO SHEDS, including garden sheds, garden beds, aviaries, storage units, garages, awnings and carports are made using high quality Australian made steel.

We are pleased to advise we warrant that the steel coating will not rust, crack, flake peel or blister for **20 years** from date of purchase, when installed within Australia.

This warranty does not apply to surface deterioration of panels caused by 'Swarf' (Tiny particles of steel debris left from cutting, grinding or drilling operations) that has not been removed after building construction, or as a result of contact with damp soil, chemicals, fertilisers or other corrosive substances.

This warranty covers any Absco product used for normal domestic use and installed in accordance with the installation instructions. The warranty does NOT cover Damage caused by storms, wind, rain snow or poor foundations.

This warranty does NOT cover ABSCO products installed in severe coastal, industrial or other highly corrosive environments. The warranty does not cover fasteners (screws, nuts, bolts, rivets, hasps or bolts).

The warranty is limited to replacement and delivery of components and does not include any labour or installation costs. The benefits given by the warranty are in addition to your other rights and remedies under a law in relation to the goods or services to which the warranty relates.

The warranty applies to the exclusion of all other representations, guarantees or warranties express or implied, our goods come with guarantees that cannot be excluded under the Australian consumer law and is not transferable. You are entitled to a replacement or refund for a major failure and for compensation for any other foreseeable loss or damage. You are also entitled to have the goods repaired or replaced if the goods fail to be of an acceptable quality and the failure does not amount to a major failure. For further information go to <http://www.consumerlaw.gov.au>.

Please retain a proof of purchase (sales docket or invoice) or register your warranty within 30 days of purchase here: www.absco.com.au/register_warranty.php

In the unlikely event a warranty claim is made, it must be supported by photographic evidence and details of the defect, including component part numbers, together with proof of purchase documentation (or on-line registration of purchase) and forwarded to the address below. Upon receipt of the warranty claim, the Customer Service Manager will contact you within three business days to advise you of the assessment outcome of the claim, which may include your expenses incurred in making the claim.

THE CUSTOMER SERVICE MANAGER, ABSCO INDUSTRIES, PO BOX 119 ACACIA RIDGE QLD AUSTRALIA 4110

PHONE: 1800 029701 FAX: 07-33441191 EMAIL: warranty@absco.com.au

Issued 01 January 2012

ABSCO SHEDS - STORAGE GUIDELINES

ABSCO SHEDS include garden sheds, garden beds, storage units, aviaries, garages, awnings and carports.

ABSCO SHEDS are designed to be weatherproof for normal weather conditions. In the event of extreme weather conditions such as heavy rain, combined with high wind gusts, the ridge capping, sheeting joints, screw fixings etc., may exhibit minor deformations which may allow some water entry. These areas should be checked regularly to ensure that maximum strength and protection is maintained.

Other weather conditions such as extreme heat and extreme cold, moist or dry air can influence the effects of concrete floor moisture and/or condensation on the underside of the roof sheets.

ABSCO SHEDS and storage units are primarily used for storage of garden equipment such as lawnmowers, wheelbarrows, garden tools etc. Storage items that might be adversely affected by any of the above conditions may require additional protection such as being sealed or covered by plastic sheets and/or stacked above the concrete floor on timber slats.

Waterproof sealants may be used to offer further protection where required around joins and screw fixings, as can rubber door seals and other products which are available from most hardware outlets.

Placement of waterproof sealants (silicone) between the base of the shed and concrete slab is not recommended, as this process can have a reverse effect, preventing excess water from escaping, resulting with water accumulating and being trapped inside the shed.

Absco accepts no responsibility for water entry, floor moisture, condensation or the condition of the Contents inside your Absco steel building arising from any of the pre-mentioned weather conditions.